

Black boxes capture car-crash data, controversy

CAPABLE OF RECORDING MECHANICAL AND HUMAN PERFORMANCE BEFORE AND DURING A CRASH, MOTOR-VEHICLE EVENT-DATA RECORDERS HAVE ATTRACTED THE ATTENTION OF SAFETY AND PRIVACY ADVOCATES.

WITH LITTLE FANFARE or customer notification, some automobile manufacturers have for years been recording your driving habits. Initially for optimizing subsystem performance, event-data recorders have now evolved into devices that can store multiple data elements, including engine speed, vehicle speed, air-bag deployment,

seat-belt use, and the state of the brakes before and during a crash. Although they are a boon to automobile designers, safety experts, insurance companies, and researchers, event recorders have also served as electronic witnesses to send more than one negligent driver to jail.

Crash statistics provide ample justification for the use of event-data recorders. Motor-vehicle accidents are the nation's largest public-health prob-

lem, resulting in a disabling injury every 14 seconds and more than a hundred deaths each day. Rajesh Subramanian, a researcher with the National Highway Traffic Safety Administration, says, "Motor-vehicle traffic crashes are the leading cause of death in the United States for people between the ages of three and 33."

Worldwide, someone dies in a vehicle crash each minute, and global fatalities number about 30 million lives since 1896. Many safety experts feel that event

At a glance	34
Now you tell us	34
For more information	38



recorders can provide the data for reducing these traffic injuries and deaths through vehicle-safety refinements, roadway improvements, and driver-behavior modification.

Although event-data recorders have been in use for years in crash research, production models have roots in automobile-air-bag-development history. As early as the 1970s, automobile manufacturers were experimenting with air bags and the sensors and circuitry necessary to activate them. Consumers were initially reluctant to pay extra for the added but unproven safety of air bags, yet designers continued to work on them and found that the controller had access to many data elements of interest to crash investigators. By the 1990s—when all automobiles required air bags—microcontrollers, solid-state memory, and in-car networks gave designers all the necessary tools for capturing system-performance and driver-reaction data throughout a crash scenario. One of General Motors' early data recorders, the sensing and diagnostic module, was instrumental in the analysis and subsequent recall in 1998 of more than 850,000 Chevrolet Cavaliers

AT A GLANCE

- ▶ Vehicle-event-data recorders capture mechanical performance and human reactions before and during a crash.
- ▶ Manufacturers, response teams, insurance companies, traffic engineers, and researchers use crash data to improve products and services.
- ▶ Event recording is a natural extension of the circuitry in the vehicle-air-bag-deployment system.
- ▶ Although you have the right to remain silent, black-box-recorder data may thwart you in a court of law.

and Pontiac Sunfires for inadvertent air-bag deployment.

The data the industry gleans from crash recorders will be invaluable for many segments of the automotive industry. Manufacturers can evaluate system performance and vehicle design to increase passenger safety. Emergency-medical teams can improve service with

automatic location notification and resource prioritization based on crash severity. Insurance providers can expedite accident investigations, identify fraudulent claims, and improve risk management. Researchers can study the cause of accidents and the effects of aging, medical disabilities, and substance abuse. Governments can improve traffic infrastructure and redesign problematic roadways. The public at large will also benefit as data recorders identify and report unsafe driving practices.

TRUTH DETECTOR

Documenting driver digressions is the most controversial application of crash-data recorders. For example, recorder data can easily reveal whether a driver was speeding or braking before an accident. Although most experts agree that recorder information belongs to the vehicle owner, it is not always easy to conceal. ACLU (American Civil Liberties Union) lawyers say that most motorists do not even know that their vehicles have the recorders and that disclosure of information from the recorder is an invasion of privacy. ACLU associate director

NOW YOU TELL US

Although manufacturers have installed event recorders in some production automobiles since the introduction of air bags, vehicle manufacturers until recently kept quiet when several states passed laws requiring consumer notification and placed restrictions on data use. An excerpt from a recent General Motors owner's manual documents vehicle data collection, discloses the existence of event-data recorders, and outlines who has access to the information:

"Your vehicle, like other modern motor vehicles, has a number of sophisticated computer systems that monitor and control several aspects of the vehicle's performance. Your vehicle uses onboard vehicle computers to monitor emission-control components to optimize fuel

economy, to monitor conditions for air-bag deployment and, if so equipped, to provide antilock braking and to help the driver control the vehicle in difficult driving situations. Some information may be stored during the regular operations to facilitate repair of detected malfunctions; other information is stored only in a crash or near-crash event by computer systems commonly called event data recorders.

In a crash or near-crash event, computer systems, such as the air-bag-sensing and diagnostic module in your vehicle may record information about the condition of the vehicle and how it was operated, such as engine speed, brake applications, throttle position, vehicle speed, safety-belt usage, air-bag readiness, air-bag performance

data, and the severity of a collision. This information has been used to improve vehicle crash performance of future vehicles and driving safety. Unlike the data recorders on many airplanes, these on-board systems do not record sounds, such as conversation of vehicle occupants.

To read this information, special equipment is needed and access to the vehicle or the SDM [sensing and diagnostic module] is required. GM will not access information about a crash event or share it with others other than

- with the consent of the vehicle owner or, if the vehicle is leased, with the consent of the lessee,
- in response to an official request of police or similar

- government office,
 - as part of GM's defense of litigation through the discovery process, or
 - as required by law.
- In addition, once GM collects or receives data, GM may
- use the data for GM research needs,
 - make it available for research where appropriate confidentially is to be maintained and need is shown, or
 - share summary data which is not tied to a specific vehicle with non-GM organizations for research purposes.

Others, such as law enforcement, may have access to the special equipment that can read the information if they have access to the vehicle or SDM."



Barry Steinhardt says, “The loss of personal civil liberties always begins with the best intentions of our government,” referring to “in-car surveillance systems.” Yet insurance companies and opposition lawyers have, to the chagrin of many drivers, successfully obtained court orders to extract recorder data after a crash (see sidebar, “Now you tell us”).

Because most modern automobiles include some type of network between subsystems, data recorders can document the state of almost every vehicle parameter. Although the most critical data elements are location, time, velocity, direction, and seat-belt status, additional information may help pinpoint mechanical failures or human error. The precrash status of the fuel level, lamp switch, turn signals, engine rotations per minute, outside temperature, seat position, number of occupants, vehicle mileage, and battery voltage may be meaningful in crash analysis. Most systems also record some type of crash-pulse information from the onboard accelerometers that activate air bags. Information about this change in velocity and direction of force may indicate the cause of the crash or the severity of injuries.

The automobile OBD (Onboard Diagnostics) network is a system for obtaining operating information for event-data recorders. Required since 1996, the OBD port facilitates inspection, allows download of emissions-related data, and, in some cases, allows adjustment of real-

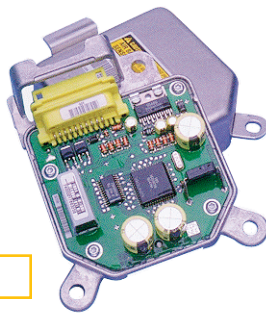

Figure 2

Delphi’s sensing and diagnostic module includes circuitry to detect crashes, deploy air bags, interface to other subsystems, and record event data.

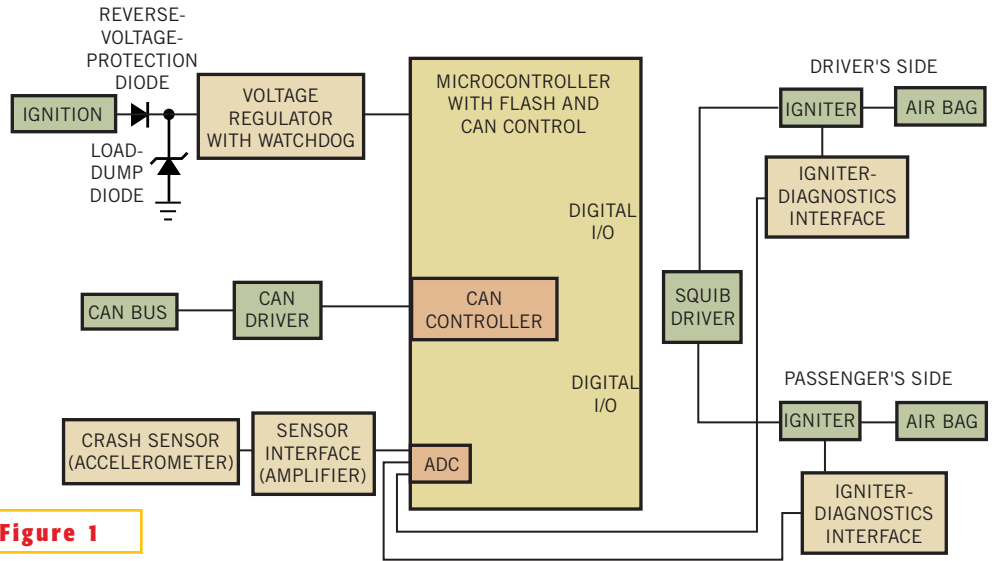

Figure 1

Manufacturers typically implement motor-vehicle event-data recorders as part of the air-bag-controller module (courtesy Toshiba America Electronic Components).

time vehicle-operating parameters. This port connects to internal electronic control units through a data network that varies depending on the manufacturer. Although the Environmental Protection Agency has mandated a common CAN (controller-area network) in all vehicles by 2008, Ford Motor Company currently uses a 41.6-kbps J1850 pulse-width-modulated data format, General Motors Corp uses a 10.4-kbps J1850 variable-pulse-width format, and most foreign cars adhere to the ISO 9141 standard. Bosch developed the CAN in 1986; the serial data-communications bus operates at data rates as high as 1 Mbps. Because of its bandwidth, the CAN bus also suits other networking tasks, such as engine management, transmission control, and entertainment systems.

A typical air-bag controller contains most of the circuitry necessary to implement an event-data recorder (Figure 1). Along with accelerometer inputs and analysis algorithms to determine when a crash occurs, the typical controller includes a squib driver with enough stored energy to blow the air bags even if battery power is disconnected. This stored energy also allows the microcontroller to continue recording data throughout a crash. A CAN-bus interface provides access to external critical data elements that the recorder captures continuously to provide a data record of events before and during the crash. A similar air-bag con-

troller, Delphi’s SDM-GF sensing and diagnostic module, senses and discriminates crash pulses (Figure 2). It contains event-data-recording capability and provides a J1850 serial-data link for vehicle systems communication.

DATA DUMP

Vetronix Corp offers a CDR (crash-data-retrieval) system that downloads precrash and crash data from the air-bag module of select General Motors and Ford vehicles to a laptop computer. The CDR system includes the hardware and Windows-based software to present crash data in graphs and tables (Figure 3). Depending on the vehicle make, model, and year, the CDR retrieves vehicle speed, engine speed, brake status, throttle position, driver’s seat-belt switch, and passenger’s air-bag-enabled or -disabled state. It also retrieves supplemental inflatable-restraint warning-lamp status, time from vehicle impact to air-bag deployment, ignition cycle count at event time, ignition cycle count at investigation, maximum change in velocity for a nondeployment event versus time for a frontal air-bag-deployment event, time from vehicle impact to time of maximum change in velocity, and time between a nondeployment and a deployment event. A nondeployment event is a crash severe enough to “wake up” the sensing algorithm but not severe enough to deploy air bags. The Vetronix CDR kit costs \$2495.

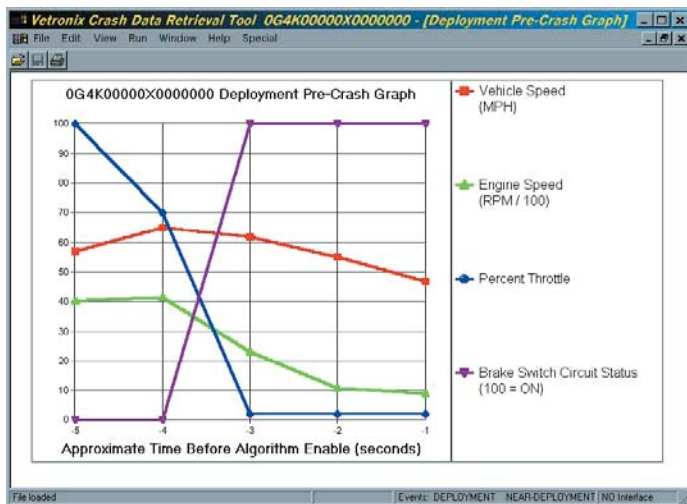

Figure 3 The Vetronix crash-data retrieval system extracts data from many General Motors and Ford vehicles and displays it in graphical format.

With vehicles traveling at more than 200 miles per hour and only inches apart, auto racing is a natural application for event-data recorders. However, it was not until after the death in 2001 of stock-car legend Dale Earnhardt that NASCAR (National Association for Stock Car Racing) began collecting real-time crash data with a black-box device from Independent Witness. NASCAR officials install the self-contained Witness unit, which has a two-year battery, next to the driver's seat (Figure 4). The device monitors vehicle motion and, in the event of impact, records the date, time, direction, impact severity, and a 3-D acceleration profile. The vendor also offers similar devices for

reducing fraud in fleet accidents by correlating the forces in a crash with subjective injury complaints.

The National Highway Traffic Safety Administration tells us that teen drivers are more than twice as likely to be involved in vehicle crashes than are adult drivers. The highest risk drivers are 16-year-olds. Road Safety International offers concerned parents a \$280 user-installed black box to monitor teen driving. The RS-1000 records vehicle-speed, g-force, brake-action, and rapid-acceleration data and then delivers an audible alert when a vehicle exceeds these limits. If a driver ignores the warning and fails to take corrective action, a steady alarm

You can reach Technical Editor Warren Webb at 1-858-513-3713, fax 1-858-486-3646, e-mail wwebb@edn.com.



tone then sounds until the driver discontinues the unsafe condition. Recorded data is available for review when the owner downloads it to a PC.

To accelerate the deployment of emerging safety technologies, the IEEE recently released standard 1616, "Motor Vehicle Event Data Recorders," which defines recorder-output data compatibility and export protocols. Although the standard does not prescribe which data elements recorders should record or how the recorders should collect and store this



Figure 4

NASCAR uses the stand-alone Witness incident-data-recording system to build a database of crash information to improve driver safety.

data, it does provide a data dictionary of 86 data elements and covers device survivability. The IEEE Vehicular Technology Society sponsored the standard, which is available online through the IEEE Standards Association.

Although the covert recording of vehicle data and driving habits may remind you of a "Big Brother is watching" scenario, crash-data recorders are here to stay (Reference 1). Thomas Kowalick, chairman of the IEEE 1616 Working Group, says, "The reason why this kind of technology must be standard on all vehicles is simply this: Motor-vehicle black boxes speak for the victims. They tell the truth in a way that nothing or no one else can." □

FOR MORE INFORMATION...

For more information on products such as those discussed in this article, contact any of the following manufacturers directly, and please let them know you read about their products in EDN.

Delphi
www.delphi.com

Environmental Protection Agency
www.epa.gov

Ford Motor Co
www.ford.com

General Motors
www.gm.com

IEEE Standards Association
standards.ieee.org

IEEE Vehicular Technology Society
www.vtsociety.org

Independent Witness
www.iwitness.com

NASCAR
www.nascar.com

National Highway Traffic Safety Administration
www.nhtsa.dot.gov

Road Safety International
www.roadsafety.com

Toshiba America Electronic Components
www.toshiba.com/taec

Vetronix Corp
www.vetronix.com

REFERENCE

1. Kowalick, Thomas M, *Fatal Exit, The Automotive Black Box Debate*, John Wiley and Sons, 2005.

TALK TO US

Post comments via TalkBack at the online version of this article at www.edn.com.